

- For stacking assemblies
- 4 pressure ranges
- Pressure reduction in ports A or P
- Model "A" with check valve
- Installation dimensions to ISO 4401/CETOP-RP 121H

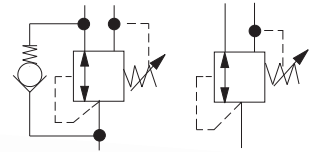

Functional Description

The pressure valves VRP2 are directly operated reducing valves for vertical stacking assemblies designed as 3 way valves, i.e. with pressure protection of the secondary circuit.

The valve consists of the valve body (1), control spool (2), spring (3), adjustment element (4) and the plug G 1/4 (5) for pressure measuring and, if necessary, of a check valve.

Model "A"

With this model, the fluid enters into the valve body from the primary circuit through port A1 and passes through the metering edge, where its pressure is reduced. The reduced pressure corresponds with the setting of the control spring. At the same time, this pressure affects also the surface area of the control spool opposed to the spring (the pressure can be measured at the port G 1/4 which is normally closed by plug 5). Thus the static balance of the spool is ensured. If the reduced pressure changes, a respective control action takes place and the reduced pressure returns to its preset value. The flow from the output port A2 passes then to the user. If pressure behind the valve increases due to the effect of the load acting on the user, the spool shifts further

against the spring until the second metering edge opens and the excessive flow drains through port T. The leakage from the spring room is also routed to port T. The reverse free-flow from port A2 to port A1 passes through a check valve which is connected parallel to the metering edge.

Model "B"

With model "B", the pressure reduction follows from port P2 to port P1, but it takes place only when the flow in port B passes in the direction to the user (not opposite). The protection of the secondary circuit is also ensured for one flow direction only.

Model "P"

With model "P", the pressure reduction follows from port P2 to port P1, but is effective in both flow directions through the directional valve (as well as the protection of the secondary circuit).

The valves are delivered with basic surface treatment. The valve body is phosphate coated, whereas the surfaces of the other parts are zinc coated.

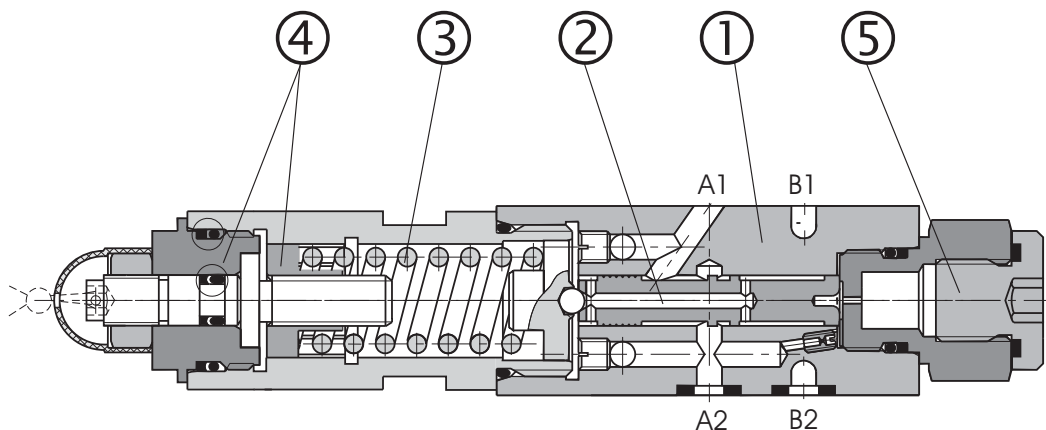

Ordering Code

VRP2-04- /

Reducing valve, directly operated

no designation

Seals
NBR

Nominal size **04 (D 02)**

Pressure range

- 2** Adjustable up to 25 bar(363 PSI)
- 6** Adjustable up to 63 bar (914 PSI)
- 16** Adjustable up to 160 bar(2321 PSI)
- 21** Adjustable up to 210 bar (3046 PSI)

Pressure reduction	Pressure control	
In port A2	from port A2	A
In port P1	from port B1	B
In port P1	from port P1	P

S Adjustment element
Screw with outside HEX 4

FOR PREFERRED TYPES SEE BOLD TYPING IN ORDERING CODE AND TABLE OF PREFERRED TYPES ON PAGE 3

Functional Symbols

VRP 2-04-A . / . .

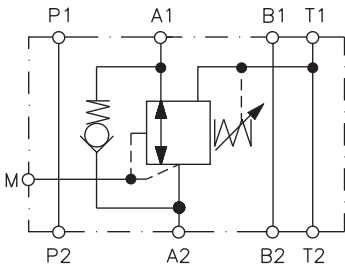

VRP 2-04-B . / . .

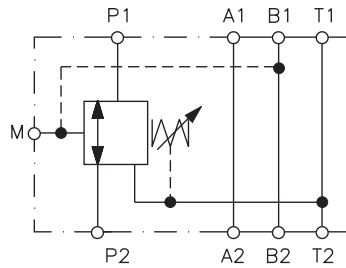

VRP 2-04-P . / . .

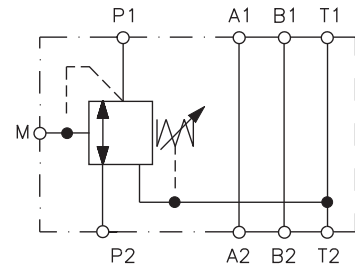

Technical Data

Nominal size	mm	04 (D02)
Maximal flow	L/min (GPM)	20 (5.3)
Max. service pressure ports (P, T, A, B)	bar (PSI)	320 (4600)
Working pressure related to flow	bar (PSI)	see p-Q characteristics
Hydraulic fluid		Hydraulic oils of power classes (HL, HLP) to DIN 51524
Fluid temperature range	°C (°F)	-30 ... +100 (-22 ... +212)
Viscosity range	mm ² /s (SUS)	20 .. 400 (98 ... 1840)
Maximum degree of fluid contamination		Class 21/18/15 to ISO 4406 (1999)
Weight - model "A"	kg (lb)	0.82 (1.81)
model "B", "P"		0.60 (1.32)
Mounting position		optional

Caution!

- The packing foil is recyclable. The protecting plate can be returned to the manufacturer.
- If the valve is used separately without a directional valve, a cover plate DK1-04/32-3 with the same installation dimensions can be ordered. This plate connect port A1 with port P1 - see catalogue Adapter and Blanking Plates HA 0003.
- Mounting bolts M5x50 or studs must be ordered separately. Tightening torque of the screws is 5 Nm (3.7 ft-lbs).
- For applications outside these parameters, please consult the manufacturer.
- The technical information regarding the product presented in this catalogue is for descriptive purposes only. It should not be construed in any case as a guaranteed representation of the product properties in the sense of the law.

p-Q Characteristics

Measured at $v = 32 \text{ mm}^2/\text{s}$ (156 SUS)

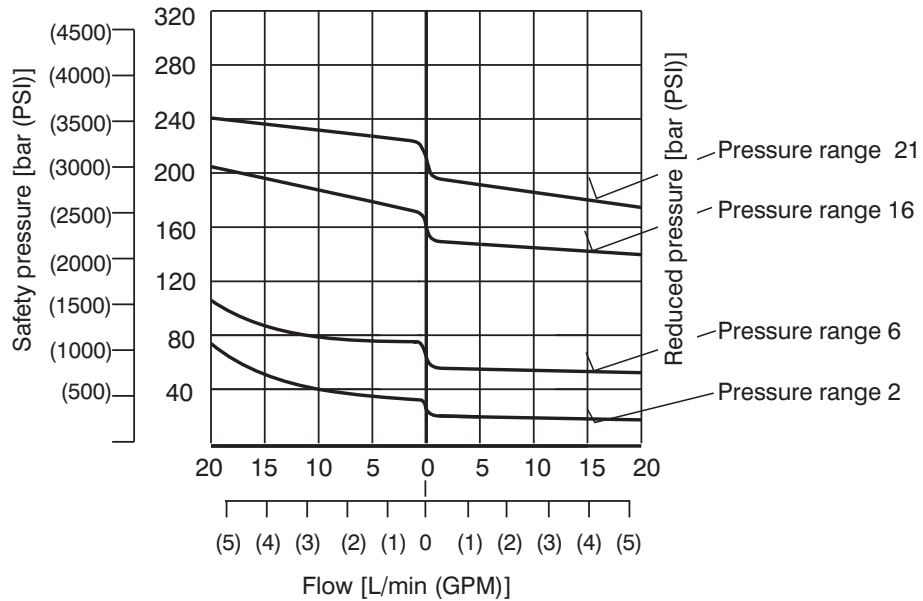

Δp -Q Characteristics

Measured at $v = 32 \text{ mm}^2/\text{s}$ (156 SUS)

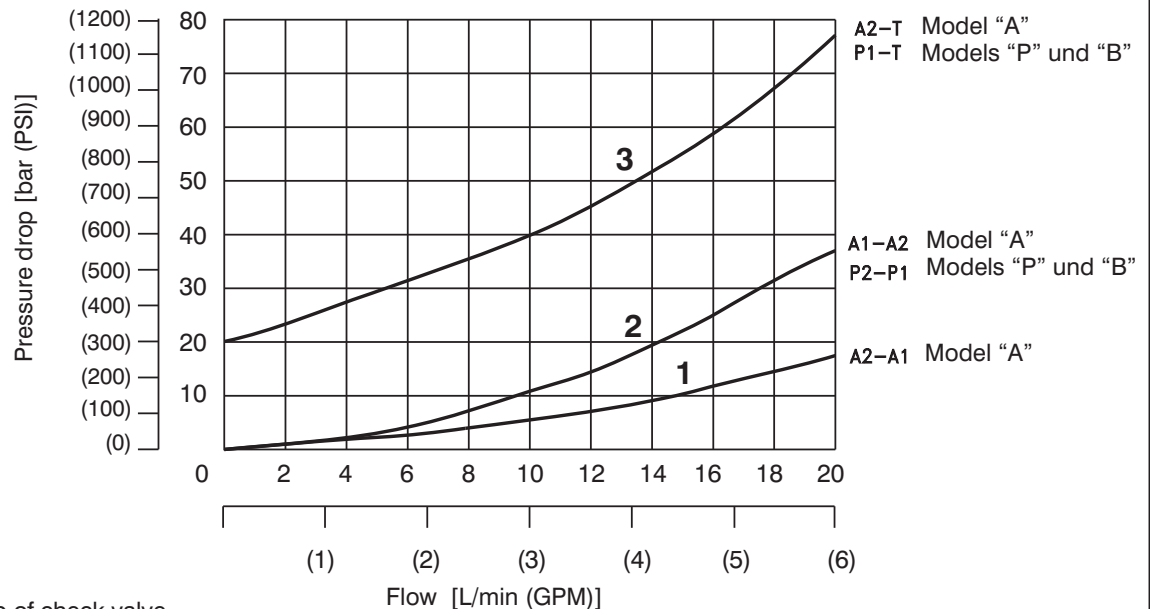

- 1 - Pressure drop of check valve
- 2 - Pressure drop of reducing valve = Min. adjustable pressure range
- 3 - Pressure drop of relief valve = Min. adjustable safety pressure

Spare Parts

Type	Dimensions, quantity	Ordering number
Standard NBR	O-ring 5 x 1,8 NBR 80 (1pcs)	517 -0030
	O-ring 12,42 x 1,78 NBR 70 (1pcs)	
	O-ring 18 x 2,65 NBR 70 (1pcs)	
	O-ring 6 x 1,5 OR1500600-N7003 (1pcs)	
	O-ring 20,35 x 1,78 ORAR00019-N9002 (1pcs)	
	DKAR 00009-N7028 5,28 x 1,68 NBR 70 (1pcs)	
	DKAR 00011-N7028 7,65x1,68 (4pcs)	
	Back-up ring BBP80B014-N9 13,16 x 15,86 x 1,14 (1pcs)	
Back-up ring BBP80B115-N962N 17,83 x 22,19 x 1,14 (1pcs)		

Preferred Types of Valves

Type	Ordering number
VRP2-04-PS/6	517-0068
VRP2-04-PS/16	517-0069
VRP2-04-PS/21	517-0070

Valve Dimensions

Dimensions in millimetres and inches

Model „A“

Type VRP2-04-AS/ ..

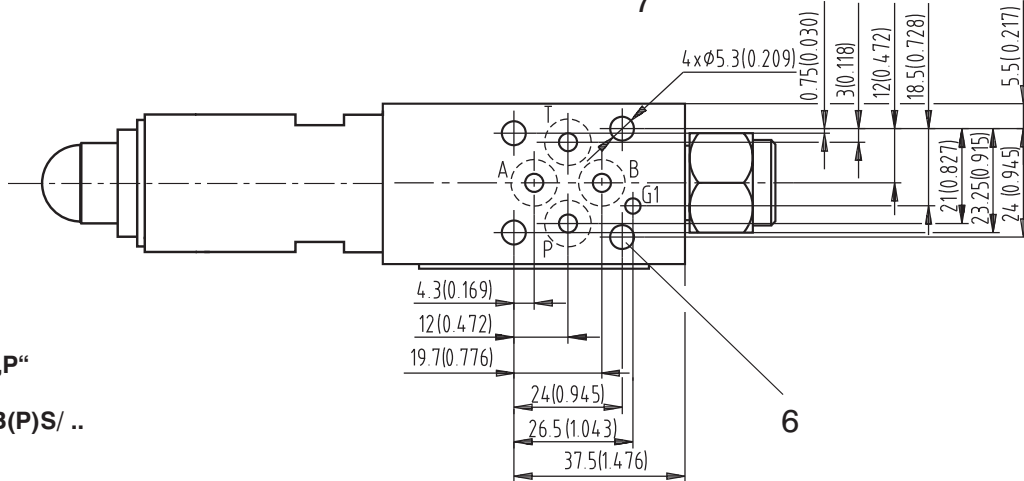
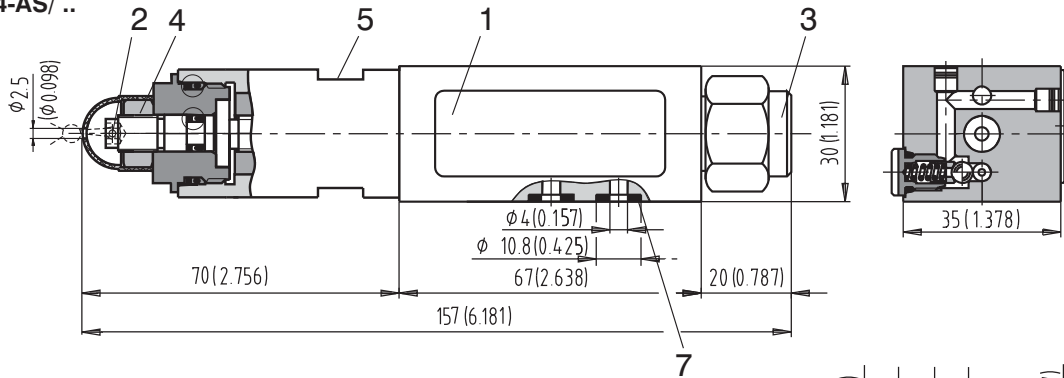

Model „B“ and „P“

Type VRP2-04-B(P)S/ ..

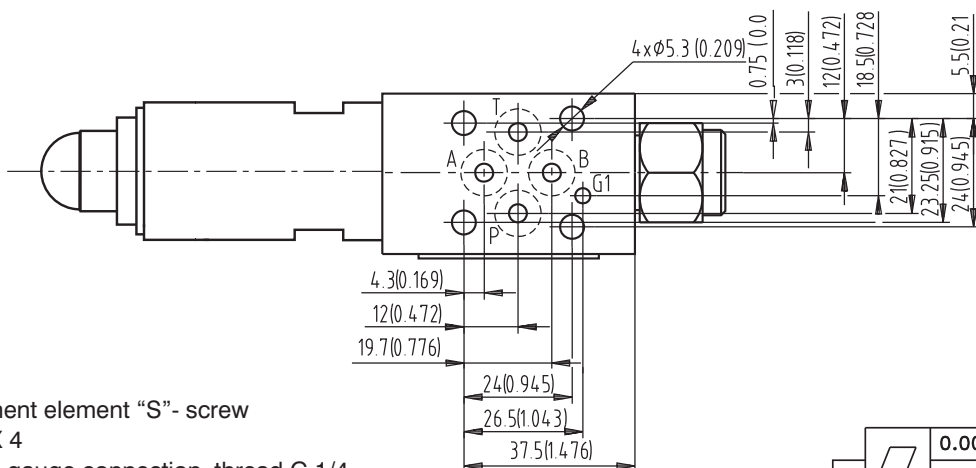
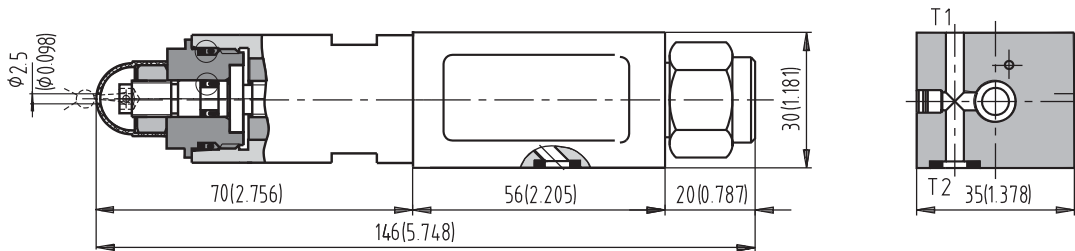

- 1 Name plate
- 2 Pressure adjustment element “S”- screw with outside HEX 4
- 3 Plug for pressure gauge connection, thread G 1/4
- 4 Locknut HEX 13
- 5 Wrench flats s=24mm
- 5 4 through mounting holes
- 6 Square ring 7.65x1.68 (4 pcs.), supplied with each valve

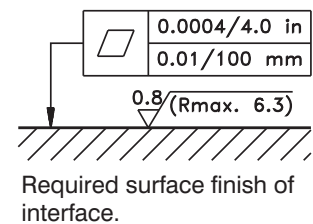

ARGO-HYTOS s.r.o. CZ - 543 15 Vrchlaví
 Tel.: +420-499-403111, Fax: +420-499-403421
 E-mail: sales.cz@argo-hytos.com
 www.argo-hytos.com