

cSt	22	30	46	68	100	150	220
f	0,4	0,6	1	1,5	2,3	3,3	4,6

CORRECTION FACTOR

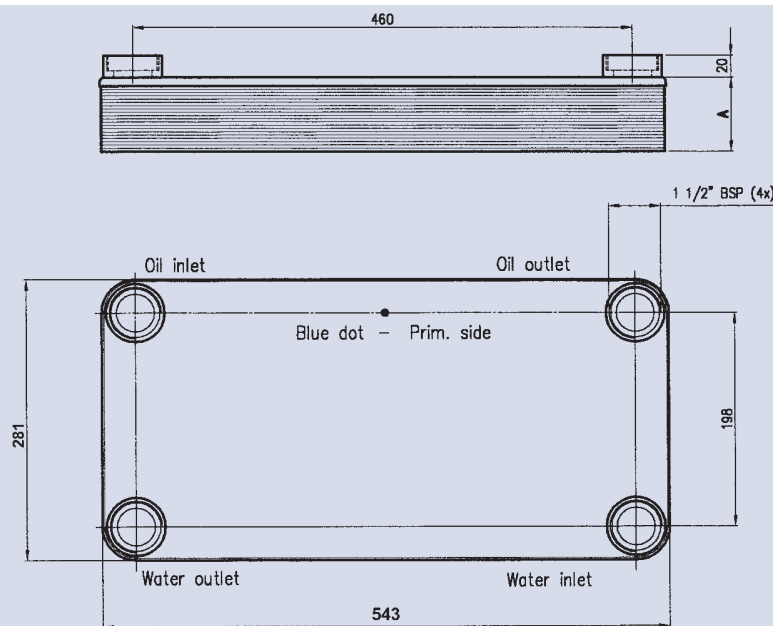

Dimensions and technical characteristics are not binding



Type	Surface m ²	Oil flow l/min	Cooling capacity kW/°C	Weight kg	Dimensions A
M55-40	2,8	80 ÷ 240	0,68 ÷ 3,24	25,7	115
M55-50	3,5	100 ÷ 300	1,47 ÷ 4,13	30,1	141
M55-60	4,2	120 ÷ 340	2,03 ÷ 5,20	34,5	167
M55-80	5,6	140 ÷ 400	2,77 ÷ 6,25	43,3	219
M55-100	7,0	160 ÷ 420	3,43 ÷ 7,00	52,1	271
M55-120	8,4	200 ÷ 440	4,41 ÷ 8,00	60,9	323

TABLE